

Sewer Overflow Alarm and Tracking System

Avoid spills and high-level conditions with early notifications

Track Manhole Surcharges and Overflows

Floats tipped by surcharges and high levels signal Mission servers to initiate notifications via phone call, email, text message, fax, and pager. Secure web portals display the date, time, and duration of the events.

Simple to Install and Maintain

The Manhole Monitor is battery operated with a quick connecting antenna and float terminations for fast and easy installation. The cellular device installs in the chimney of the manhole using a versatile mounting bracket. The bracket allows the waterproof device to swivel upward during maintenance for convenient and easy removal. The unique in-ground antenna installs adjacent to the manhole. Installation can be completed with common tools and does not require manhole cover modifications or entry into the manhole. An optional “under-the-lid” mounting bracket is available for original equipment manufacturer (OEM) lid applications.

Waterproof, Self-Contained, and Safe in Sewers

The rugged, all-metal enclosure is robust and serviceable. It features a replaceable battery, isolated termination, and electronic cavities. The intrinsically safe device meets requirements for use in hazardous sewer system environments and is designed and tested to IP68 specifications.

User-Friendly

Startup is simple with a 16-character LCD that validates proper operation and displays optional advanced configuration settings. The user-accessible pushbutton switch allows navigation through the display. Alternate languages can be selected.

Reliable Communications

The advanced Manhole Monitor features fourth generation (4G) radios for reliable data transmissions. The device features fully acknowledged data payloads—unlike SMS messages. There are no radios to program, cellular contracts to set up, or software programs to buy.

Managed Service—The Complete Package

The service includes all communications, data storage, alarm call-outs, reports, and technical support. Alarm conditions are recorded and reported in real-time while device health status is transmitted daily. All data and reports can be accessed from any web-enabled device, and the data is archived forever. No engineering or programming is required.

Long Operating Life

The ultra-efficient circuitry draws minimal power from the field replaceable battery. This makes the low-power device capable of routine daily transmissions for more than five years.



- Receive alarms and data on surcharges and overflows
- Fully managed service includes communications, alarm call-outs and web portals
- 4G radio for reliable data transmission
- Rugged, all-metal, waterproof enclosure
- LCD simplifies startup and optional advanced settings
- High-capacity, 5-year, field replaceable battery

Dimensions

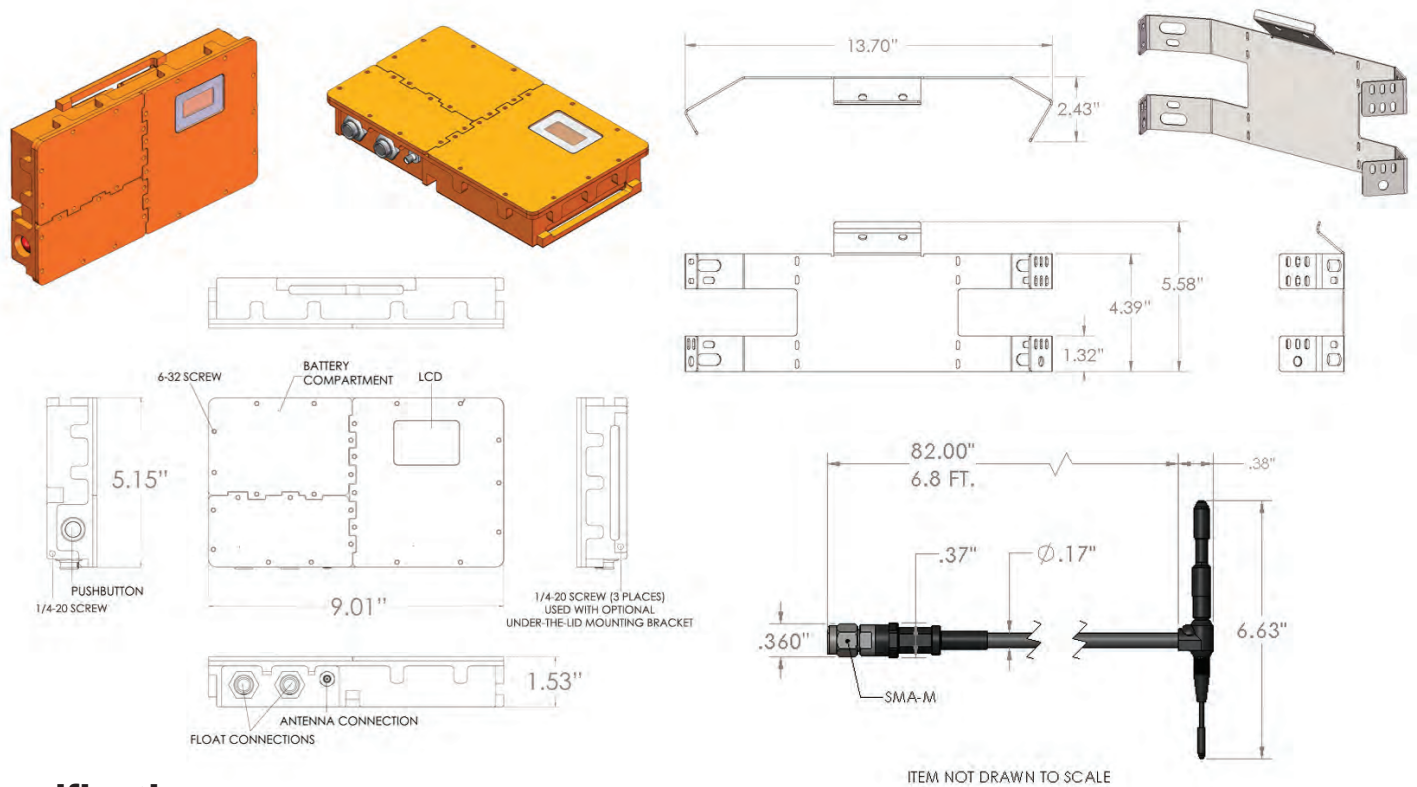

Specifications

Enclosure:

- Solid aluminum enclosure with serviceable compartments
- Double-coated for corrosion resistance
- Polycarbonate display lens

Power:

- Replaceable 6.0 VDC lithium manganese dioxide battery
- 36.6 watt-hour capacity
- 5 year nominal lifetime

Float Inputs:

- (2) Dry contact inputs
- Alarms on state change
- Configurable debounce delay for nuisance alarm prevention
- (2) Mercury-free floats; 2 wire, 20' water resistant, safety colored cable, normally-closed, mechanically-activated, 90 degree open
- Floats terminated with molded SwitchCraft EN3 harsh environment connector with integral O-Ring and locking bayonet

Radios:

- 4G cellular modem
- Five-band UMTS/HSPA+ (800/850/AWS1700/1900/2100 MHz) and quad-band GSM/GPRS, EDGE (850/900/1800/1900 MHz)
- Triple Band CDMA2000 (800/1900MHz), 3GPP2: 1xAdvanced, EV-DO Rev.A

Antenna:

- In-ground, omnidirectional (PN RF8003)
- Water-tight SMA male (cable) to SMA female (enclosure) connection

Included Installation Hardware:

- Stainless steel, multifaceted mounting bracket
- TapCon stainless steel masonry bolts, (4) 1" x 3/4" and (2) 2" x 1/4"
- (1) 3/16" diameter masonry drill bit
- (2) Carabiners
- Tie wraps
- Asphalt sealant
- Drying agent

Physical:

- Enclosure: 9.01" L x 1.53" W x 5.15" H
- Enclosure: 3.6 lbs.
- CAD files available for enclosure and mounting bracket

Configuration and Diagnostics:

- Liquid crystal display (LCD)
- Pushbutton switch
- Device information
- Optional configuration parameters
- Language selection (English, Spanish and French)

Environment:

- Operating: -10 to 50°C
- LCD: 0 to 60°C
- Intrinsically safe, Certified Class I, II, III, Division 1 Groups D-G, T1 hazardous environments
- Independently tested for IP68 rating—water proof up to depths of 10' for four hours and 4' for 24 hours
- EU RoHS compliant

Warranty:

- Enclosure and electronics: 5 years
- Battery: 5 years based on 500 transmissions per year*
- Floats: 1 year

*Additional service plans available for higher data transmission rates.

Optional Accessories:

- Above-ground antenna (PN RF8006)
- Replacement in-ground antenna (PN RF8003)
- Pole mount antenna kit (PN RF8005)
- Replacement battery pack (PN PW8202)
- 10' Float (PN IT8503)
- 20' Float (PN IT8502)
- 30' Float (PN IT8504)
- Masonry drill bit, 3/8" x 24" (PN T8000)
- Under-the-lid mounting bracket (PN E8113)



(877) 993-1911 • sales@123mc.com • 123mc.com

©2018 Mission Communications. The Mission Communications logo is property of Mission Communications. All Rights Reserved. Protected under patents 7,216, 145. Specifications subject to change without notice.



Certified Class I, II, III, Division 1 Groups D-G, T1 and Intrinsically Safe.

Literature Code: MM-0118